

NOTE: BREAK ALL CORNERS WITH 0.015" (.38 MM) RADIUS UNLESS OTHERWISE SPECIFIED. STANDARD TOLERANCES TO APPLY UNLESS OTHERWISE SPECIFIED.

CUSTOMER CAN ART STD.	DIE No. EH05944	REV. No. 1
DESCRIPTION 2.000 x 0.187 ROUND TUBE	CUSTOMER PART No.	PROPOSAL No. H-21544
	QUOTE No. 09-0933-1	

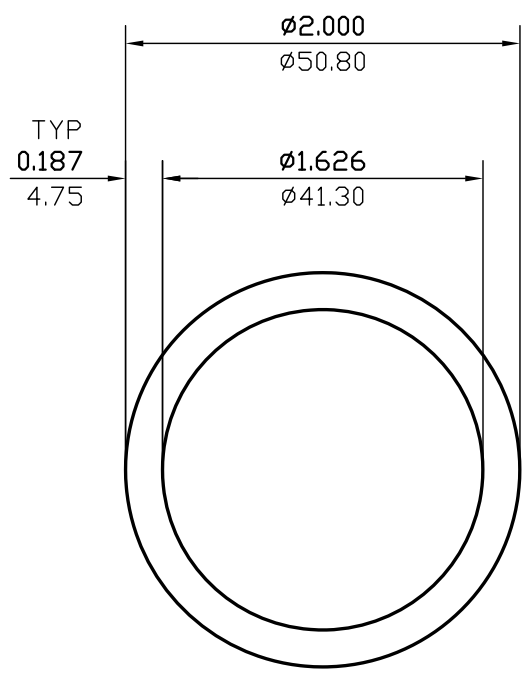

WALL THICKNESS **0.187 (4.75)** EXCEPT AS SHOWN

DATE	REV	DESCRIPTION	BY
03/10/23	1	REMOVED ALLOY	JASON
EST.AREA	1.065	IN. ²	EST.AREA
			687.164
			MM. ²
EST.WT.	1.257	LBS/FT.	EST.WT.
			1.870
			KG/M.
EST.PER.	11.391	IN.	EST.PER.
			289.342
			MM.
OUT PER.	6.283	IN.	OUT PER.
			159.6
			MM.
C.C.D.	2.000	IN.	C.C.D.
			50.800
			MM.
FINISH	M/F		ALLOY
CKD BY	FACTOR 9	SCALE 1:1	DWN BY P.M. DATE 08/27/2009

CAN ART

ALUMINUM EXTRUSION INC.

85 PARKSHORE DRIVE
BRAMPTON, ONT L6T 5M1
TEL. NO. (905) 791-1464
FAX NO. (905) 791-9151
WEB: www.canart.com

THIS DRAWING IS NOT NECESSARILY A COPY OF YOUR ORIGINAL. PLEASE APPROVE DIMENSIONS AND TOLERANCES INDICATED. CAN ART ASSUMES NO RESPONSIBILITY EITHER TECHNICAL OR LEGAL FOR HAVING THIS SHAPE MADE. THE CUSTOMER AGREES TO FULLY PROTECT CAN ART ALUMINUM FROM CLAIMS OF OTHERS RESULTING FROM THIS SHAPE.

SIGNED: _____ DATE: _____